

## Design and characterization of an end-pumped Nd: YAG microlaser

R. Dabu, A. Stratan, L. Neagu

National Institute for Lasers, Plasma, and Radiation Physics, P.O. Box MG-36, 077125, Bucharest, Romania

(Received May 30, 2003)

*Abstract.* We describe a microlaser longitudinally pumped by a laser diode with maximum 4W of cw power at 808 nm. Microlaser generates Q-switched laser pulses obtained by using a saturable absorber ( $\text{Cr}^{4+}$ : YAG) in the laser resonator. Laser resonator is shorter than 20-mm. Pump radiation is focused with an optical collimation/focusing system. The optical-to-optical efficiency of the laser system is maximum when the dimensions of the pumped Nd: YAG rod volumes are dimensions comparable with those of the fundamental mode. Quasi-continuously pumped with 1.5W, the microlaser generates pulses with 13 $\mu\text{J}$  energy, 2 ns pulse width, and 900 Hz, repetition rate, at 1064 nm wavelength.

### Introduction

Diode-laser-pumped solid state lasers appeared recently on the laser-market and they imposed themselves by two major advantages: a major grow of pumping efficiency, an order higher of magnitude in comparison with the flash lamp pumped lasers, and the elimination of expensive and big water cooling systems [1].

In this paper we describe a micro-laser pumped by a quasi-continuum laser diode. A higher pump-intensity can be obtained with this kind of diode operation comparing with the continuum pumped micro-lasers, with a significant reduction of system complexity and price.

Microlaser device presented in this paper is an efficient, compact, passively Q-switched laser, which uses  $\text{Cr}^{4+}$ : YAG as a saturable absorber.

Microlaser output radiation has some distinct features: high power pulses (dozens of kW); nanosecond pulse duration; high pulse frequency repetition (from mono-pulse to 1-2 kHz); narrow spectral band, high quality propagation beam ( $\text{TEM}_{00}$ ); simple structure and operation.

### Experimental set-up

Microlaser system consists in the driver unit, the laser head, which contains the pump diode laser, and the collimation/focusing optical system active medium, saturable absorber and the output-coupling mirror.

Schematic set-up of the microlaser device is shown in the Fig.1:

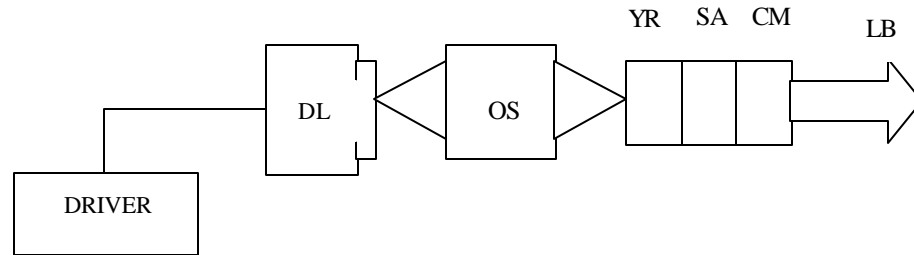

Fig.1 - Schematic set-up of the microlaser; **DL** : pump diode laser; **OS**: collimation/focusing optical system; **YR**: Nd:YAG rod ; **SA**: saturable absorber; **CM**: coupling mirror; **LB**: laser beam-

**Driver unit** supplies the diode laser with a current well filtered and stabilized, and keeps the working temperature of the diode laser. Driver unit supplies a current pulse with regularized amplitude (maximum 6 A), which allows reaching the nominal optical-power (1-4 W) of the high-brightness DL. Pumping-pulse duration is settled between 0.1-0.25 ms, with the repetition-frequency of max. 1 kHz.

Laser diode temperature is measured with a thermistor placed near the active junction of the device. Diode laser temperature control is performed with a Peltier-element fixed on the diode laser radiator.

Driver unit has an essential role in obtaining a reproducible laser device operation. To secure the diode laser lifetime of as much as thousands hours, the diode laser have to work at a power level which represent 25-50 % of the limit value which produces the irreversible damage of the device. A lifetime growth can be obtained by reducing the diode current and the diode working temperature.

Diode-laser is a reliable device in normal conditions, as well as other semiconductor devices, but it is very vulnerable to electrical parameter overgrowth, even for short periods of time of nanosecond order. Driver unit must deliver a law-noise level current for an efficient protection of the laser diode against the overloaded voltage.

Pump radiation can be coupled to the microchip laser using GRIN lenses [6] or aspheric lenses AR coated at 808 nm.

**Optical system** collects, collimates and focuses the pump beam emitted by the laser-diode on the active medium. The maximum laser-system efficiency is obtained when the pump-radiation has its transverse dimensions compatible with those of the fundamental transversal mode ( $TEM_{00}$ ) of the laser resonator inside the active medium. Reducing the pumping spot by shortening the focal length of the lens is still limited by the pump beam confocal parameter shortening. Excessive reducing of confocal parameter provides an important variation of the pump beam transverse dimension in the active medium along the propagation direction, which reduces the laser efficiency.

**Diode laser.** The optical power and the emission aperture of the diode laser are essential to achieve the desired pumping of the active medium. A small diode aperture and a high-brightness laser diode make possible a pump-beam, which can be focalized inside the  $TEM_{00}$  on the entire active medium absorption length.

**Laser resonator** of the microlaser passively Q-switched device was realized in two variants: with discrete components (Nd: YAG active medium, Cr<sup>4+</sup>: YAG saturable absorber, laser beam extraction mirror) or in a microchip technology. Pump radiation can be coupled to the microchip laser using GRIN lenses [6] or aspheric lenses AR coated at 808 nm.

Schematic set-up of a laser resonator with discrete components is shown in Fig. 2.

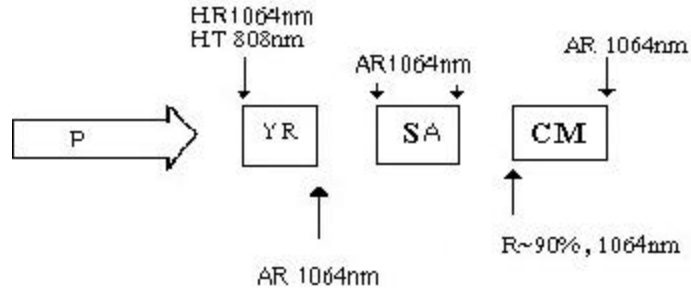

Fig.2 - Laser resonator with discrete optical components. **YR**: active medium Nd: YAG; **SA**: saturable absorber Cr: YAG; **CM**: coupling mirror; **P**: pump beam; **HR**: high-reflectivity dielectric coating; **AR**: antireflective dielectric coating -.

The output face of the Nd:YAG crystal is coated with a dichroic mirror with HR (> 99.8%) at 1064 nm and high transmission (T >90%) at 808 nm. The inner face of the active medium is AR coated at 1064 nm. Saturable absorber Cr<sup>4+</sup>:YAG crystal with faces AR coated at 1064 nm, is placed in the laser resonator near the active medium. Laser beam is extracted from the resonator through the output mirror, CM 85-90 % reflective at 1064 nm. The CM output face is AR coated at 1064 nm.

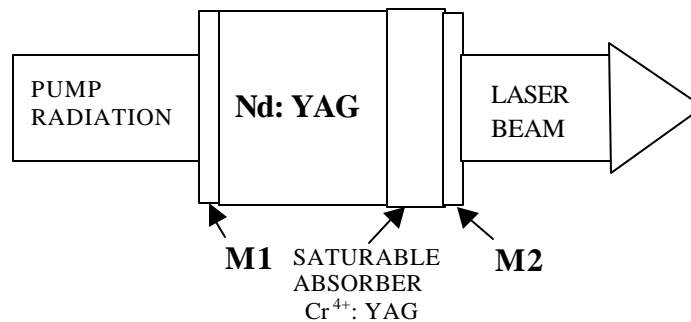

Fig.3 - Microchip laser resonator. Nd: YAG: laser active medium; M1: dichroic laser mirror (HR at 1064 nm, HT at 808 nm); M 2: laser mirror partial reflective at 1064 nm -.

Micro-laser monolithic resonator (made by VLOC USA) 3.5 mm length, 3 mm diameter, plane-plane type, contains a Nd:YAG rod (3 mm length) bonded by optical

contact with a Cr<sup>4+</sup>:YAG rod (0.5 mm length). Both external faces of the two plates are plane, normally cut on the optic axis, and polished at laser standards. Nd: YAG rod is doped with an atomic concentration of 1.1 % Nd. Cr<sup>4+</sup>:YAG crystal initial transmission at small signal at 1064 nm wavelength is  $T_i = 87\%$ . The output face of the active medium is coated with a plane dichroic mirror with high reflectivity  $R_{las} > 99.8\%$ , at 1064 nm laser wavelength and high transmission  $T_{1p} > 90\%$  at 808 nm pump radiation wavelength. This face is the high-reflectivity mirror of laser resonator. The external face of Cr<sup>4+</sup>: YAG crystal is coated with the micro-laser output mirror (93% reflectivity at 1064 nm).

## Results and discussion

The characteristic values of Nd: YAG active media, Cr<sup>4+</sup>: YAG saturable absorber and laser resonator used for the micro-laser system parameters calculation are presented in Table 1.

Table 1- Characteristic parameters used in calculations

Parameter name	Symbol	Value
Laser emission cross section	$\sigma_{las}$	$6 \times 10^{-19} \text{ cm}^{-2}$
Upper level lifetime	$t$	230 ms
Nd: YAG refractive index	$n$	1.82
Nd: YAG thermal conductivity	$k$	$13 \text{ Wm}^{-1}\text{K}^{-1}$
Absorption coefficient of the pump radiation in the laser rod	$a$	$7.1 \text{ cm}^{-1}$
Thermal dispersion coefficient of the Refractive index of Nd: YAG	$\frac{dn}{dT}$	$7.3 \times 10^{-6} \text{ K}^{-1}$
Laser diode spectral bandwidth	$\Delta\lambda_p$	2.3 nm

Working parameters of the microlaser for different pump radiation powers, pump pulse durations, resonator lengths, and initial transmissions of the Cr:YAG crystal are given in the Table 2.

The characteristics of the microlaser emitted radiation beam have been calculated using the following equations [2,9,12]:

$$R_e = \frac{2pk r^2}{cV_{abs}} \quad (1)$$

where  $R_e$  is the equivalent curvature radius of pumped face of Nd:YAG rod due to thermal effect;

$V = 1 - \frac{I_p}{I_L} \approx 0.24$  is the conversion factor of the absorbed pumping energy to

dissipated heat in the active media  $C = \left[ \frac{\partial n}{\partial T} + (1 + \nu)n\alpha_T \right]$ ;  $dn/dT$  is the refractive index gradient with temperature;  $\nu$  is the Poisson coefficient;  $n$  refractive index of active media;  $\alpha_T$  is the thermal expansion coefficient;  $r$  is the average radius of pumped volume inside the active media;  $k$  is the Nd:YAG thermal conductivity;

The TEM<sub>00</sub> radius ( $w$ ) is approximated by:

$$w \cong \sqrt{\frac{I_L}{P}(R_e L_e)} \quad (2)$$

where:

$\lambda_L$  is laser wavelength;

$L_e = L/n$  is the equivalent length of the microlaser cavity;

The single laser pulse energy ( $E_{out}$ ) is given by:

$$E_{out} = E_{st} h k_e \quad (3)$$

$$k_e = \frac{g_{out}}{g_{out} + g_p}$$

$$h = \frac{n_i - n_f}{n_i}$$

$$n_f - n_i = n_t \ln \frac{n_f}{n_i}$$

$$n_i = n_{0,th} = \frac{g_{sat} + g_p + g_{out}}{2s_{las} l_{ma}}$$

$$n_t = \frac{g_p + g_{out}}{2s_{las} l_{ma}}$$

$k_e$  is the laser energy extraction factor from resonator by output mirror;

$n_i$  is the population inversion in the active medium when the Q-switched pulse is starting;  $n_t$  is the population inversion for oscillation threshold in the presence of the saturated absorber;  $n_f$  is the final population inversion after the Q-switched pulsed

generation;  $g_{out}$  are the output coupling losses;  $g_{sat}$  the saturable losses;  $g_p$  the unsaturable resonator losses;  $l_{ma}$  is the Nd:YAG length.

The laser pulse delay is ( $t_{th}$ ):

$$t_{th} = -\tau \ln \left( 1 - \frac{n_{0,th}}{W_p \tau} \right) \quad (4)$$

where  $\tau$  is the upper laser level lifetime.

Table 2. -Specification of the Nd:YAG micro-laser-.

<b>Pump</b>	<b>3.1 W /pulse, 900 Hz, duration 360 ms</b>	<b>4.2 W / pulse, 900 Hz, duration 430 ms</b>
<b>Cr: YAG crystal transmission, <math>T_i</math></b>	<b>0.87</b>	<b>0.82</b>
<b>Optical length resonator, <math>L</math> [mm]</b>	<b>13</b>	<b>28</b>
<b>Coupling factor of the pump radiation inside the volume of the microlaser transversal fundamental mode (<math>TEM_{00}</math>), <math>f_s</math></b>	<b>0.4</b>	<b>0.4</b>
<b>Pump rate, <math>W_p</math> [<math>cm^{-3} s^{-1}</math>]</b>	<b><math>3.896 \times 10^{21}</math></b>	<b><math>4.244 \times 10^{21}</math></b>
<b>Equivalent mirror radius, <math>R_e</math> [m]</b>	<b>5.38</b>	<b>3.33</b>
<b>TEM<sub>00</sub>, <math>w</math> [mm] radius</b>	<b>0.279</b>	<b>0.312</b>
<b>Energy / pulse calculated, <math>E_{out}</math> [mJ]</b>	<b>49</b>	<b>68</b>
<b>Energy / pulse measured, <math>E_{out}</math> [mJ]</b>	<b>45</b>	<b>66</b>
<b>Laser pulse duration measured, <math>t_w</math> [ns]</b>	<b>9.5</b>	<b>10</b>
<b>Laser pulse delay calculated, <math>t_{th}</math> [ms]</b>	<b>219</b>	<b>333</b>
<b>Laser pulse delay measured, <math>t_{th}</math> [ms]</b>	<b>230</b>	<b>390</b>

The experimental set-up used to measure the microlaser characteristics is shown in Fig.4.

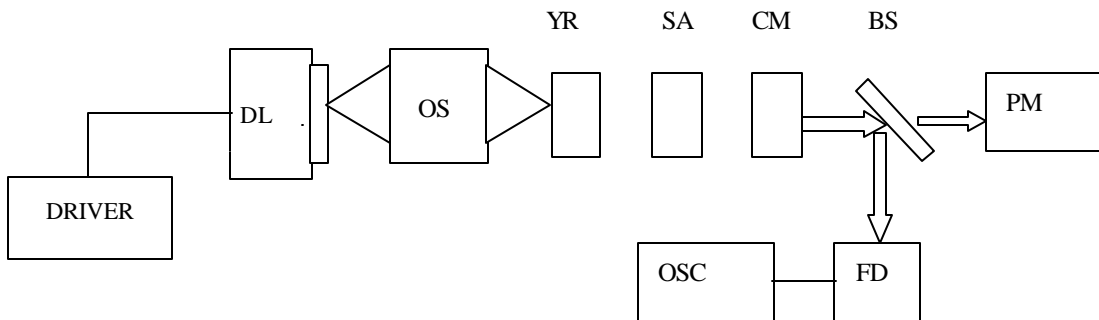

Fig.4 - The experimental setup of the microlaser system: DL – laser diode; OS –optical system; YR–Nd: YAG active medium; A – saturable absorber; CM – extraction mirror; BS – beam splitter; PM– powermeter; FD – fast photodiode; OSC – large band oscilloscope –.

The focal plane of the laser diode is placed inside the Nd: YAG rod, near the input face. The saturable absorber, Cr: YAG crystal, is located inside the resonator to get the passively Q-switched mode of operation. The output mirror coated by a partial reflecting mirror is placed in an adjustable mount for easy optical alignment.

The following pump parameters were measured:

- current pulse amplitude into laser diode: continuum adjustable in 0.5-4 A range;
- current pulse duration: continuum adjustable in 50 – 550  $\mu$ s range;
- current pulse repetition frequency adjustable in several steps: 200, 400, 900 Hz  $\pm$  10 %;
- current pulse amplitude fluctuation: less than  $\pm$  0.5%;
- limit of the current by the protection circuit: 4 A;
- laser diode temperature: continuum adjustable in 15 – 35  $^{\circ}$ C range;
- laser diode temperature fluctuation: less than  $\pm$  0.5%;
- optical power of the laser diode as a function of the laser diode current (L-I characteristic, fig.5.);

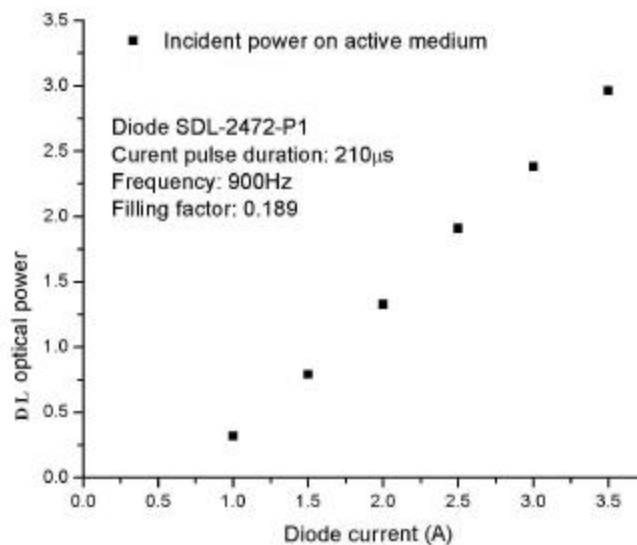
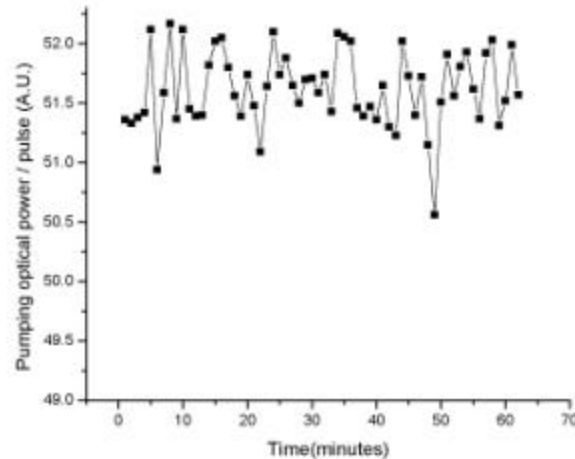

Fig. 5. - The pump system efficiency characteristic for SDL 2472-P1 laser –.

- transmission (T) of the collimating optical system:  $T \geq 96$  %;
- optical power fluctuations for the laser diode: less than  $\pm$  1 %.

The average value  $V_m$  and standard error  $\mathbf{s}$  were determined for the measured



value:  $V_m = 51.62$  a.u. and  $\mathbf{s} = 0.32$  a.u., corresponding to a  $\pm 0.62$  % fluctuation for the pump optical power reported to the average value of the measurements (fig.6.).

Fig. 6. - Temporal evolution of the pump optical power -.

Experimental results have demonstrated the stable and reproducible working regime of pumping system at the nominal working parameters of the laser diode.

We have investigated the working parameters of the monolithic microchip laser.

The transversal distribution of the beam intensity was measured with a laser beam analyzer (Spiricon LBA 100) equipped with an infrared CCD camera. A dominant  $TEM_{00}$  structure was identified as results from fig. 7 (3D profile) and 8 (2D profile). A 0.887 fit with the theoretical Gaussian profile was found. The beam diameter on the extraction mirror has been estimated at about  $300\mu\text{m}$ , a value that corresponds to a 2.2 mrad angular divergence. The slight asymmetry of the output beam is given by the imperfect matching of the focused pump beam to the  $TEM_{00}$  volume (fig.7,8).

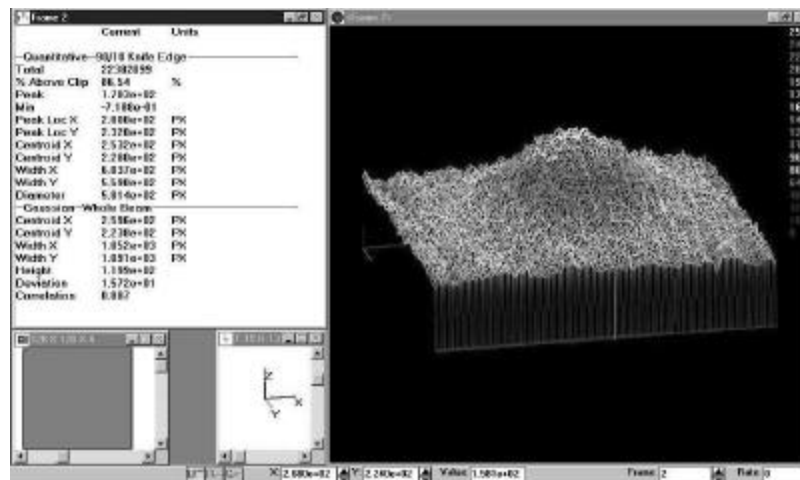

Fig. 7 - Transversal intensity profile of the laser beam (3D) -.

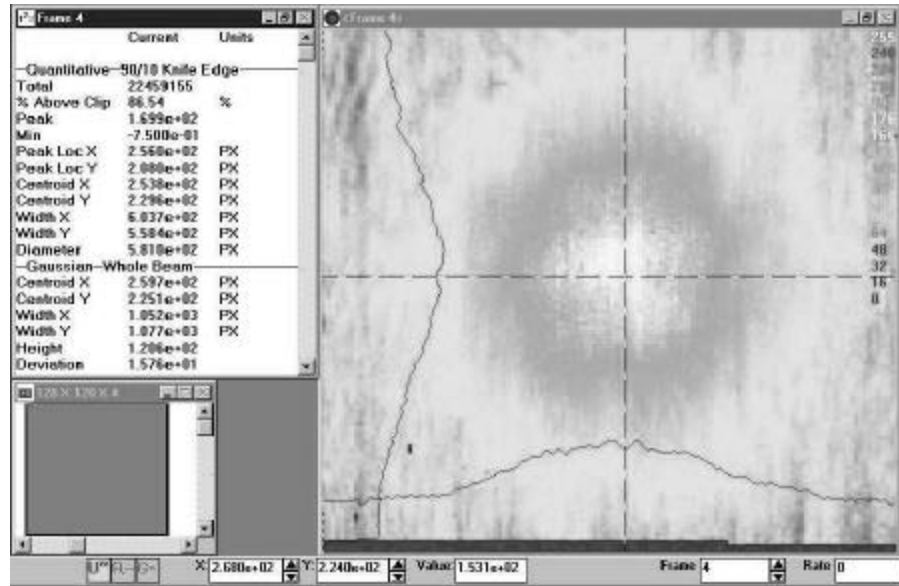

Fig. 8 - Transversal intensity profile of the laser beam (2D) -.

The optical pump power was about 1.5 W/pulse with a pulse frequency of 900 Hz. The measured average beam power was 11.5 mW (after remanent pump radiation subtraction) that correspond to 13  $\mu$ J laser pulse energy.

The stability tests have been made for the following beam parameters:

- beam average power;
- laser pulse energy;
- pulse duration and pulse shape for the laser beam (temporal profile).

The stability test conditions:

- pump power: 1.5 W/pulse (single pulse regime);
- pump pulse duration: 210  $\mu$ s;
- pulse repetition frequency: 900 Hz;
- working temperature of the pump laser diode: 29 °C;
- ambient temperature: 25-30 °C;

All tests start 30 minutes after the laser diode drive was plugged and all nominal pump parameters were stable. The test duration is 1 h. During the tests none of the pump parameters were changed. The results of our tests are presented in fig. 9 (a and b) and 10.

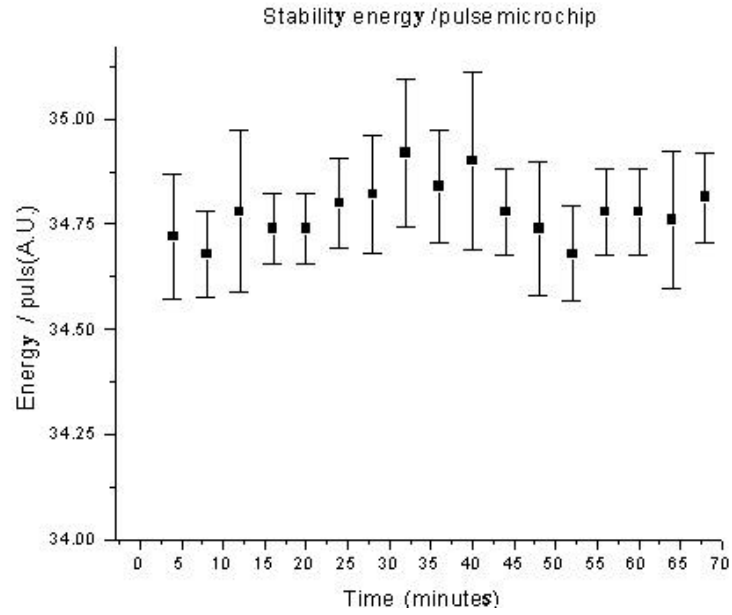

(a)

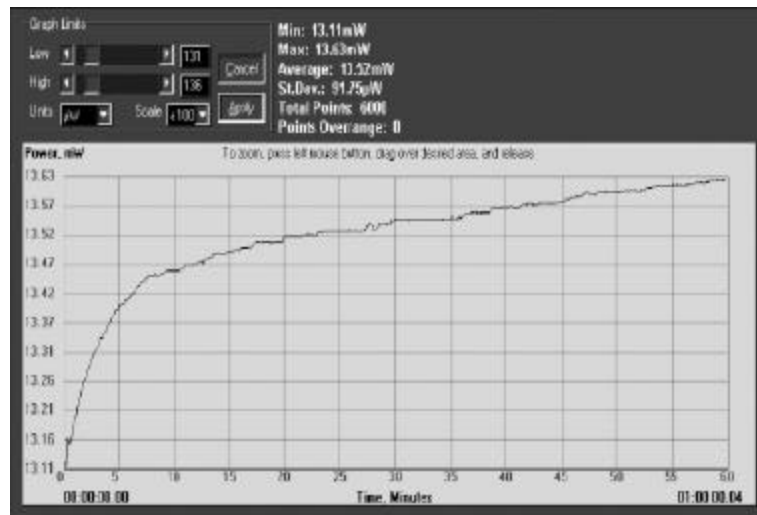

(b)

Fig.9 - The time evolution of the average beam power (a) and the laser pulse energy (b) generated by the microlaser system -.

The stability of the laser pulse energy was measured with a large area silicon photodiode, which was plugged to a digital oscilloscope (Tektronix TDS 724A). Based on the above results, the fluctuations of the average beam power and laser peak energy were estimated to be less than  $\pm 0.6\%$  for one hour.

The stability of the laser pulse duration and pulse shape was investigated with a fast photodiode (D400FC) coupled by an optical fiber to the oscilloscope.

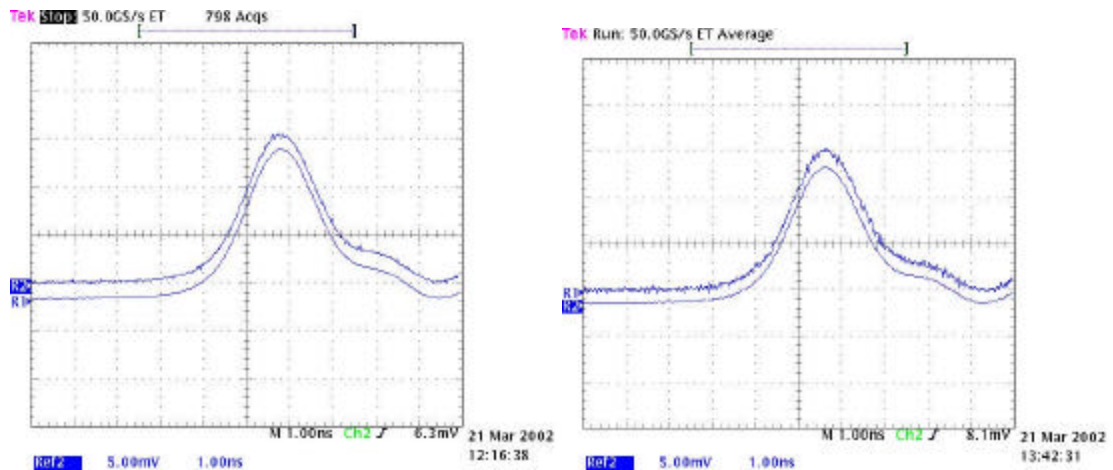

Fig. 10. -The time evolution of the laser pulse temporal profile -.

In each diagram from fig.10 are presented two records from the digital oscilloscope. R1 represents the temporal profile single of a laser pulse. The high stability of the pulse shape is demonstrated by R 2 record, which represents the laser pulse envelope averaged over 64 consecutive pulses. The full width at the half maximum (FWHM) duration of the laser pulse is about 2 ns.

### Conclusions

We have developed a microchip laser system at the 1064 nm wavelength. The extracted pulse energy was  $13\mu\text{J}$  and the pulse duration was 2 ns at 900 Hz pulse repetition rate.

The microlaser has the advantage of miniaturization and very high stability of the pulse duration and temporal profile. The monolithic technology offers a high mechanical stability.

Due to the short size of the microchip resonator, only few longitudinal modes can oscillate offering the possibility to select a single longitudinal mode operation with a very narrow spectral bandwidth.

Due to their spectral characteristics, high beam quality, and long-term stability, the microlasers can be applied in material processing, holography, optical ranging, spectroscopy, and research of nonlinear optics [3,5,6].

## REFERENCES

1. J. J. Zayhowski and C. Dill III, *Optics Letters*, 17, No. 17 (1992).
2. J. J. Zayhowski and C. Dill III, *Opt. Lett.* 19, No. 18, p. 1427 (1994).
3. J. J. Zayhowski, *Laser Focus World* 35, No. 8, pp. 129 (1999).
4. J. J. Zayhowski, *Opt. Lett.* 22, No. 3, p. 169 (1997).
5. L. Marshall, *Laser Focus World* 34, No. 6, 63 (1998).
6. D. Guillot, *Laser Focus World* 36, No. 6, 81 (2000).
7. B. V. Zhdanov et al., *Am. J. Phys.*, 68 (3), pp. 282 (2000).
8. A. K. Cousins, *Applied Optics* 31, No. 34, p. 7259 (1992).
9. C. Pfistner et al., *IEEE Journal of Quantum Electronics* 30, No.7, p. 1605 (1994).
10. J. Song et al., *Opt. Comm.* 177, p.307 (2000).
11. K. W. Aniolek et al., *Opt. Lett.* 25, No. 8, p. 557 (2000).
12. W. Koechner, *Solid-State Laser Engineering*, Springer-Verlag, Berlin Heidelberg, 1988, p.175.