

OPTICAL CHARACTERIZATION OF A MAGNETIC FLUID ADAPTIVE MIRROR

V. DAMIAN, D. APOSTOL, M. BOJAN, L. SERGHEI, F. GAROI, I. IORDACHE,
P.C. LOGOFATU, V. NASCOV

National Institute for Laser Plasma and Radiation Physics damian@ifin.nipne.ro

(Received March 14, 2006)

Abstract. In order to develop an optical adaptive mirror with magnetic fluid we need to characterize the optical behaviour of the fluid. We measured the spectral reflectivity of different magnetic fluids and compared them with the basic fluid. The behaviour of the magnetic fluids mirror in external magnetic fields was also studied.

Key words: magnetic fluid, optics, spectral reflectivity, interferometry.

1. INTRODUCTION

The main subject of our paper is adaptive optics dedicated to astronomical telescopes. In order to build bigger and cheaper telescopes scientists had to come with new ideas that satisfy these requirements. One solution is an old one: the use of liquids mirrors. The other one is the use of magnetic fluids.

In this paper we will be concerned with the optical characterization of the fluid and the adaptive system, built with it.

The need for new types of adaptive systems that use magnetic fluids, especially for large telescope mirrors, generates a lot of problems, not only related with the design of the system but also related with the physics of such a system [1, 2, 3].

2. OPTICS OF MAGNETIC LIQUIDS

In order to describe the optical properties of the magnetic liquids to be used for adaptive systems, we started with the most important characteristic: the spectral reflectivity of the fluid. As the spectral domain of interest is the one in the visible region, we plotted our spectra in the 300-900 nm range for liquids with different magnetizations.

As radiation is not monochromatic, the reflectivity characteristic is described analytically by a wavelength dependent relation, namely [4]:

$$R(\lambda, \theta_i) \equiv \frac{1}{2} \left(\frac{n_i^2(\lambda) \cos^2 \theta_i + J(\lambda, \theta_i) - 2n_i(\lambda) \cos \theta_i \sqrt{J(\lambda, \theta_i)}}{n_i^2(\lambda) \cos^2 \theta_i + J(\lambda, \theta_i) + 2n_i(\lambda) \cos \theta_i \sqrt{J(\lambda, \theta_i)}} \right) + \frac{n_t^2(\lambda) \cos^2 \theta_i + n_t^2(\lambda) J(\lambda, \theta_i) - 2n_i(\lambda) \cos \theta_i \sqrt{J(\lambda, \theta_i)}}{n_t^2(\lambda) \cos^2 \theta_i + n_t^2(\lambda) J(\lambda, \theta_i) + 2n_i(\lambda) \cos \theta_i \sqrt{J(\lambda, \theta_i)}}$$

where $n_{it} = n_t/n_i$ is the relative refractive index of the two media and

$$J(\lambda, \theta_i) = n_i^2(\lambda) - n_t^2(\lambda) + n_t^2(\lambda) \cos(\theta_i)$$

Thus, it is almost impossible to map the theoretical plot of reflectivity, if we consider the complexity of the refractive index determination as a function of wavelength. We determined only experimental reflection spectra [6,7].

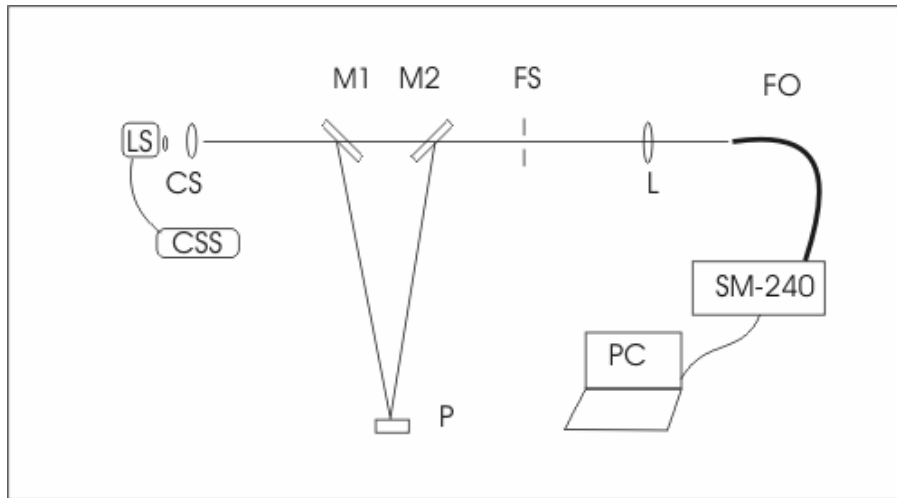

Fig. 1 – radiation source; CS – light collimator; M1, M2-mirrors; CSS – stabilized power supply; P – sample; FS – spatial filter; L- lens; FO – optical fiber; SM – 240 – spectrophotometer; PC – computer.

Fig. 1 shows the experimental arrangement for measuring the spectra. As light source we used a quartz bulb (35 W, 12 V) powered by a DC power supply (adjustable EHQ Power PS 3020: 0 – 30 V, 0 – 20 A).

When working with liquids, for a correct measurement on the air/liquid interface, we need to do a “vertical” arrangement and so it is important that the incidence angle be as small as possible. We were able to get a 12° incidence angle on the air/liquid boundary using two mirrors, M1 and M2, as in Fig. 1. A lens L focuses the radiation onto the entrance slit of a UV-VIS optical fiber coupled with the SM-240 CCD spectrometer (Spectral Products, USA). The spectrograph (a

crossed Czerny-Turner type) has an F/2.7 aperture and 1200 grooves/mm holographic grating. Radiation spectra were taken with a linear charge coupled device (CCD) sensor array (Toshiba CCD array) and they were recorded by the optical multichannel analyzer (OMA). The wavelength range was 200–900 nm with a spectral resolution of about 1.5 nm. Although, the time resolution of the system (determined by the OMA time reading) was 5 ms, the reflected light was measured using integration times of 20–40 ms, depending on the light intensity. The system is driven by a computer with a dedicated soft, and the spectra were recorded as ASCII files.

As reference for our experiments we measured the reflection spectrum of an aluminium mirror. For this, we placed the aluminium mirror in the same place as the magnetic liquid pot (Fig. 2). Due to the fact that reflection of the Al mirror is well determined (89% at 633 nm), an absolute evaluation of the reflectivity is possible at this wavelength.

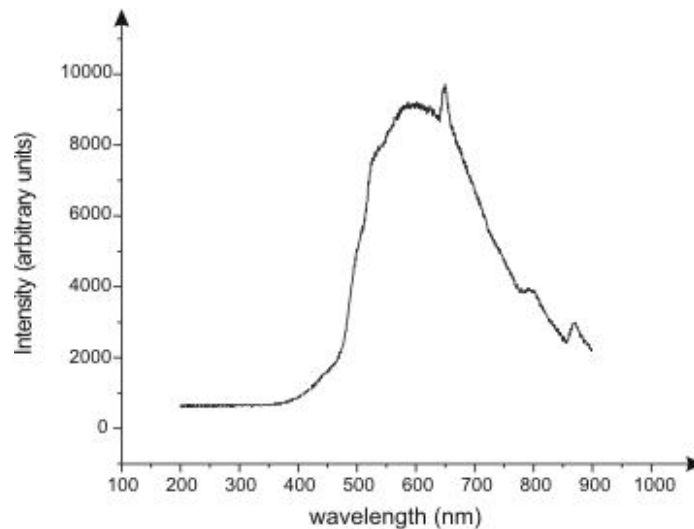

Fig. 2 – Reference spectrum.

We recorded the spectra for different magnetic liquids with different magnetizations, base liquids and surfactants. The spectra plotted in Figs. 3–5 are normalized to one unit of the integration time and relative to the reference spectrum. As can be seen, we used two kinds of base liquids: water and oil (TR 30).

Fig. 3 shows the reflection spectrum of a magnetic liquid having as a basic fluid water with 80Gs magnetization compared with the water spectrum and reflection of the dried pot.

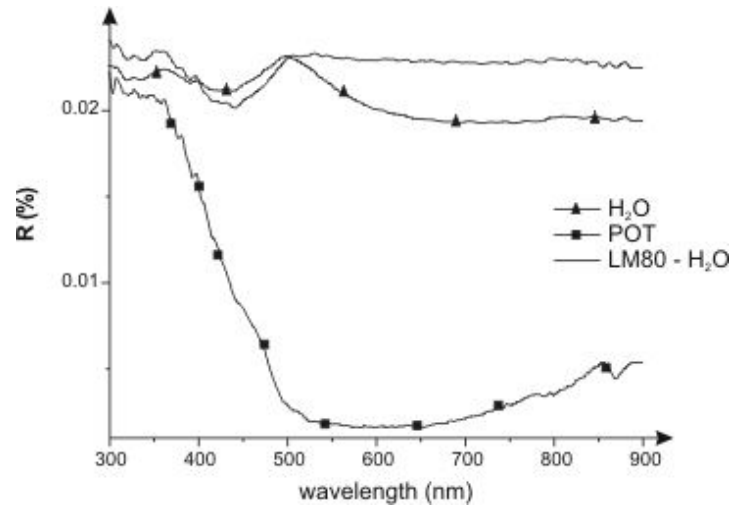

Fig. 3 – Reflection spectra: water, pot and magnetic fluid (LM80-H₂O).

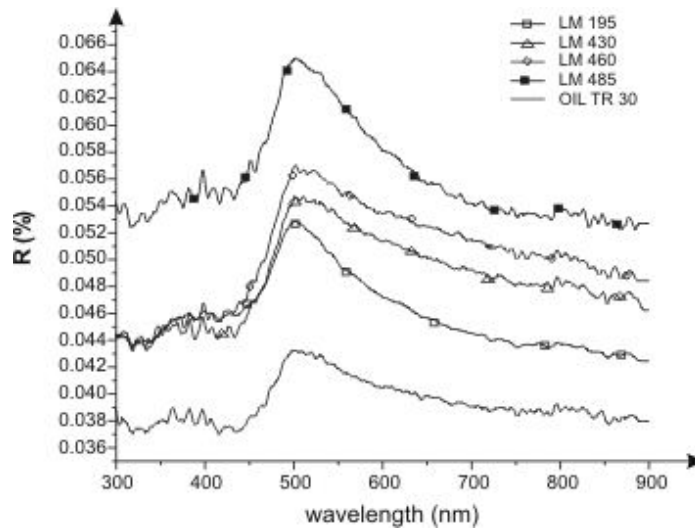

Fig. 4 – Reflection spectra of magnetic fluids in oil with different magnetizations and oleic acid as surfactants.

Fig. 4 presents the reflection spectra of several magnetic fluids in oil with different magnetizations (195, 430, 460 and 485 Gs) having as surfactants oleic acid [9, 10]. These spectra are compared with the reflection spectra of the transformer oil (TR-30) that was used as base fluid.

The last set of measurements represented in Fig. 5 are the reflection spectra of magnetic fluids with different magnetizations (515, 714, 730, 741 Gs) and with different acid surfactants (lauric, miristic, oleic and a mixture: miristic and oleic).

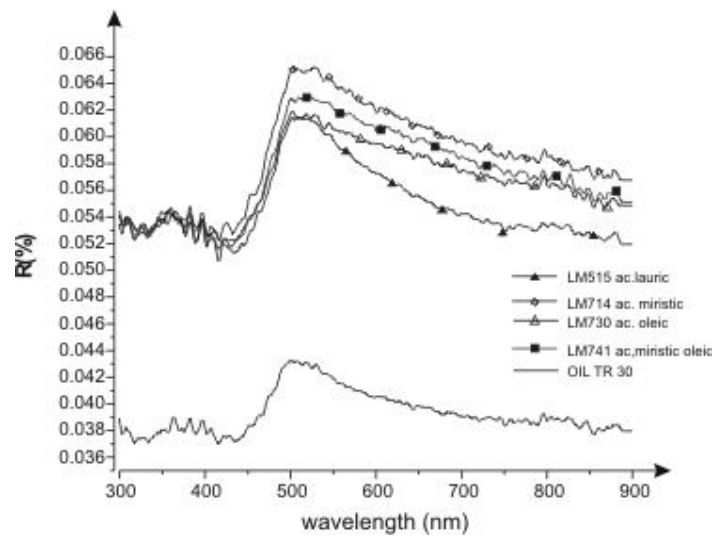

Fig. 5 – Reflection spectra of magnetic fluids in oil with different magnetization and different acid as surfactants.

As a general observation, it can be seen that the reflection spectrum is dictated by the magnetical substance, its density (that is correlated with the magnetization) and is influenced by the surfactants. The contribution of the base liquid is not very evident taking into account the small value of its reflection coefficient.

Generally, the reflection coefficient of the studied magnetic fluids is in the range 0.018 to 0.057 at 633 nm as determined from the reflection of the aluminum mirror.

Another issue we had to deal with was how the magnetic field used in the modulation of the liquid mirror's surface influences the polarization of the incident radiation (*e.g.*, introducing a birefringence).

In Fig. 6 you can see the optical arrangement for polarimetric analysis. This arrangement resembles the one used for optical spectrum measurement, the only difference being a polarization analyser (A). Also, the measurements were done using a prism monochromator and a photodetector. Our arrangement is the most sensitive at 530 nm. This is why the measurements were conducted at this particular wavelength [5].

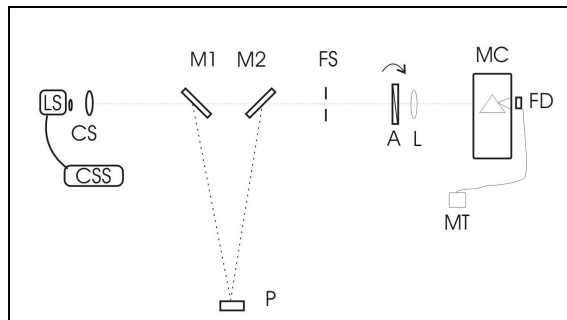

Fig. 6 – LS – radiation source, CS – light collimator, M1, M2 – mirrors, CSS – stabilized power supply, P-probe, FS – spatial filter, L- lens, MC – Monochromator, FD – fotodetector, MT – measuring system, A – analyzer.

The radiation source was originally unpolarized. However, when analysed after passing through the setup, there was a small degree of polarization due to absorption on metallic surfaces of the deflecting mirrors (Fig. 7). In the case of the magnetic fluid the reflected light is even more polarized.

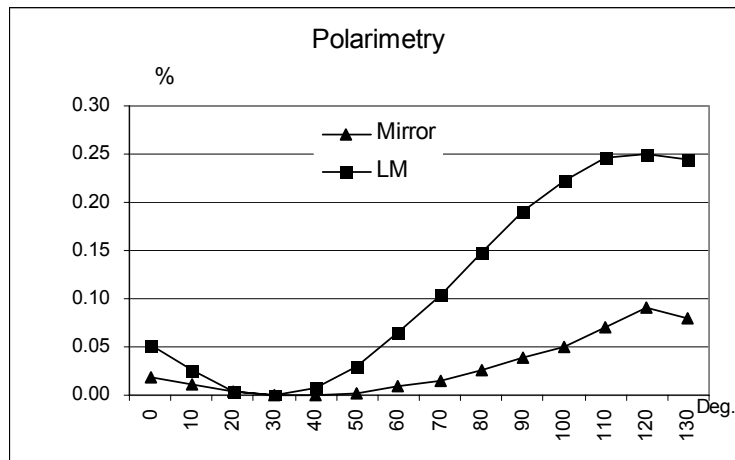

Fig. 7 – Polarimetric measurements on mirrors and magnetic liquid.

We worked with small magnetic fields, created with a solenoid, and we did not observe any birefringence phenomena in the presence of the external magnetic field (Fig. 8). The magnetic fields developed by the solenoid surrounding (in a horizontal plane) the magnetic liquid pot are relatively small: 28 Gs @ 2 A, in the center of the solenoid. This value is big enough to modulate the surface of the liquid, as can be seen in the interferogram presented in Fig. 9 [7].

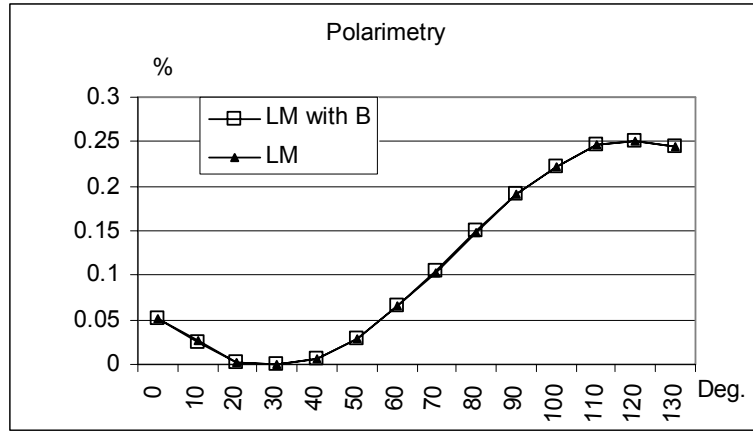

Fig. 8 – Polarimetric measurements on magnetic liquid mirror with and without external magnetic field.

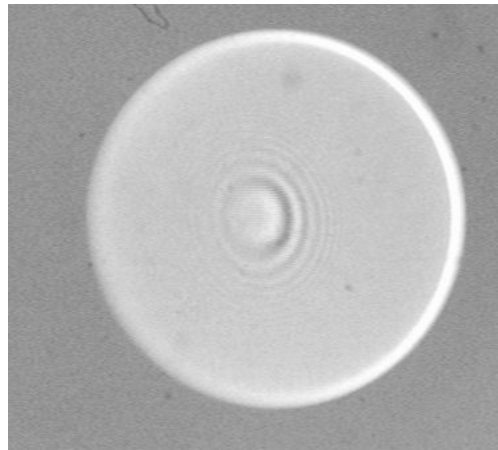

Fig. 9 – The interferogram of the magnetic liquid mirror deformed by a surrounding solenoid.

3. ADAPTIVE OPTICAL SYSTEM WITH MAGNETIC LIQUID

The experimental device used to analyze the optical adaptive system is presented in Fig. 10 [8].

The pot with external diameter of 120 mm, an internal diameter of 100 mm and height of 3 mm is filled with magnetic liquid. Under this small tank the actuation system is placed: a network of coils with ferrite core (D3 – of high frequency), placed at 10 mm distance from each other.

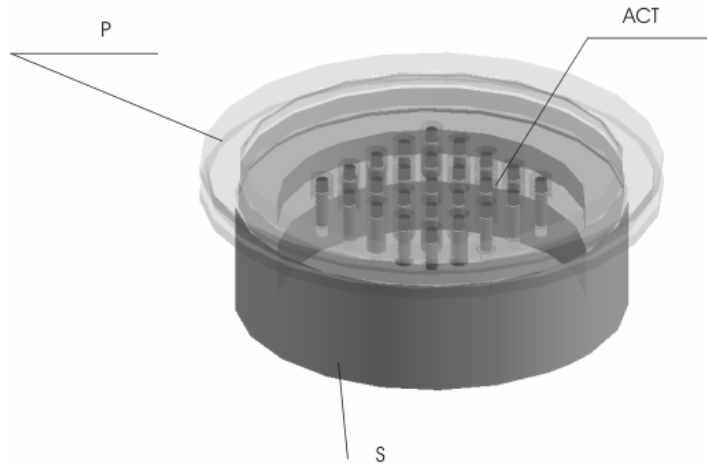

Fig. 10 – P – pot with magnetic liquid, ACT – actuators, S – support system.

In order to test and observe the characteristics of the surface (of the magnetic liquid) created using these actuators, we monitor the surface of the liquid with a Fizeau-Möller interferometer with $\phi = 110$ mm. All images are recorded on a computer using a Baxall CCD camera connected to a frame grabber.

Knowing, from the measurements described above, the spectral properties (maximum reflectivity at 520 – 540 nm) of the magnetic liquid, we used as radiation source the Hg lamp ($\lambda = 546$ nm). Two cases of interferometric figure were taken into account: with reference fringes (Fizeau fringes) and without reference fringes (the two surfaces are quasi parallel).

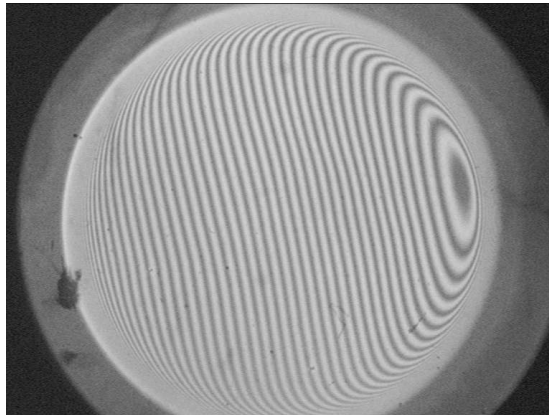

Fig 11 – Plane magnetic liquid mirror (interferogram with Fizeau fringe).

Analysing the surface of the magnetic liquid mirror, when no disturbance is applied (Fig. 11), we can observe both the planicity of the surface (the etalon has a planicity of $\lambda/50$) and the interface phenomena due to superficial tensions.

For small diameter tanks, these tensions can become big enough and can “spoil” the entire surface. The interferogram is realised with reference fringes.

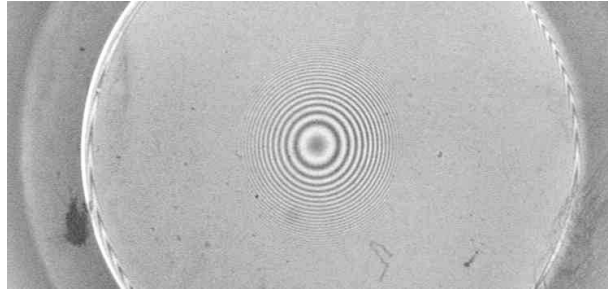

Fig. 12 – Mirror's deformation when a toroidal magnetic field is applied.

Fig. 12 presents an interferogram that is obtained when the magnetic liquid mirror is distorted in the presence of a magnetic field. The field is created with a permanent toroidal magnet ($\Phi_{\text{ext}} = 100$ mm, $\Phi_{\text{int}} = 50$ mm) placed at a distance of 73 mm under the mirror.

It can be seen that the resultant force (given by composition of the forces due to the magnetic field and gravity) acting on the fluid, gives rise to a quasi-spherical surface in the center of the interferogram. This deformation has a radius of curvature of 8 m and is concave.

The next pictures (Figs. 13–15) demonstrate the possibility to modulate the magnetic liquid mirror.

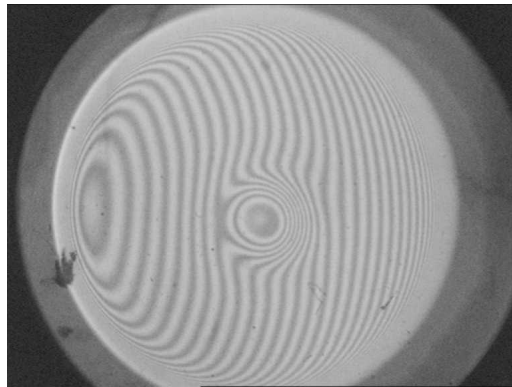

Fig. 13 – Liquid mirror with one actuator active.

Tests and measurements were realised for various currents in the actuator's coils and for different configurations of the modulation elements (pixels or actuators).

It was determined that for currents in the domain 0–0.5 A, a useful deformation of the mirror's surface is obtained. From the interferometric measurement, the maximum deformation for the maximum current is of the order of 1 μm . This value is small enough and far from the critical points of the magnetic fluid of approximately 1 mm*.

The first picture (Fig. 13) presents the deformation of the surface with one actuator. Figs. 14 and 15 show a system of three linear elements (pixels) distorting the liquid mirror in two cases: with and without reference fringes. In the first case it is easier to evaluate the deformation while the second case gives better visual information.

In the last 3 images we presented the moment when a 0.5 A current passed through the actuators.

A nonuniformity of the image is easily seen. The reason for this is that the actuators do not have their apex in the same plane, and the coupling with the magnetic liquid is different for each of them.

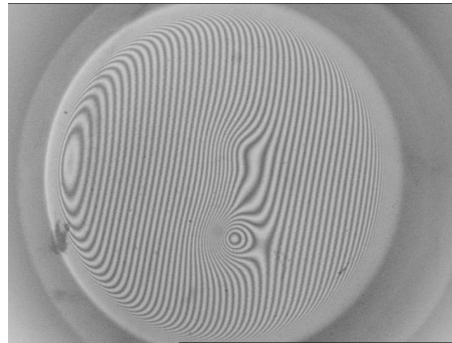

Fig. 14 – Three linear actuators with reference fringes acting on the liquid mirror.



Fig. 15 – Three linear actuators without reference fringes acting on the liquid mirror.

4. CONCLUSION

In this paper we presented the optical experimental behaviour (reflectivity) and the functionality of an adaptive system with magnetic liquid.

The pure magnetic liquid mirror is not useful because of its low spectral reflectivity (a maximum in the green region is 6% and depends on the magnetic particle concentration correlated with the type of the base fluid and surfactants).

The reflectivity could be improved by development of a MELLF* (Metal Liquid-Like Film) liquid, which can be coated on the surface of the oil. This MELLF is a thin film (smaller than 200 μm in width) composed of silver nanoparticles that float on the surface of a liquid [7,11].

Water is the natural substrate for MELLF, but new techniques to deposit them on oily surfaces has been developed. These oily surfaces have to be chemically stable and must have a reasonable viscosity. The reflectivity of such oils in the visible region of the spectrum can be of 80% or greater.

We have demonstrated that we can build an experimental arrangement for an adaptive magnetic liquid mirror. The setup can be improved by increasing the liquid-actuators coupling uniformity.

The possibility was also shown to use such a system as information transmitter by “writing” the logo of the work group ILA.

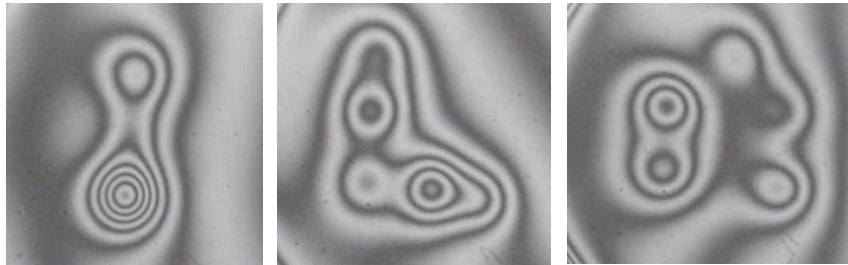

Acknowledgements. The authors thank the members of the Lab. of Magnetic Fluids, CFATR, Romanian Academy – Timișoara Division, and the National Center for Engineering of Systems with Complex Fluids – Univ. “Politehnica” Timișoara, Romania, who prepared the necessary magnetic fluids.

We acknowledge the financial support of this work by ROSA, the AEROSPACE programme, grant number 111/10.2004.

REFERENCES

1. *Adaptive optics in astronomy* Ed. Francois Roddier, Cambridge University Press (1999).
2. E.F. Borra, et. al., *Liquid Mirrors: Optical Shop Tests and Contributions to the Technology*, *Astrophys. J.* 393, 829–847 (1992).

3. D. Bica, *Preparation of magnetic fluids for various applications*, Rom. Rep. Phys., **47**, Nos. 3–5, 265–272, (1995).
4. E. Angelopoulou, S. Poger, *The color of specular highlights*, Proceedings of the SPIE Conference on Electronic Imaging, vol. 5009, January 2003.
5. J. Depeyrot *et al.*, *Static Magneto Optical Birefringence of New Electric Double Layered Magnetic Fluids*, Brazilian Journal of Physics, vol.31, no.3, Sept., (2001).
6. G. Tremblay, E.F. Borra, *Optical Tests of a 3.7-m diameter Liquid Mirror: Behavior under External Perturbations* Applied Optics, Vol. 39, no. 36, 5651 (2001).
7. E. F. Borra, A.M. Ritcey, E. Artigau, *Floating Mirrors*, ApJ Letters, 516, L115, (1999).
8. O. Cugat, *et al.*, *Deformable magnetic mirror for adaptive optics: technological aspects*, Sensors and Actuators A 89 1–9, (2001).
9. L. Vekas, M. Rasa, D. Bica, *Physical properties of magnetic fluids and nanoparticles from magnetic and magneto-rheological measurements*, J.Colloid&Interface Sci. 231,247–254(2000).
10. M. Rasa, D. Bica, A. Philipse, L. Vekas, *Dilution series approach for investigation of microstructural properties and particle interactions in high-quality magnetic fluids*, Eur.Phys.J. E, E7, 209–220(2002).
11. Hélène Yockell-Lelièvre *et al.*, *Optical Tests of Nanoengineered Liquid Mirrors*, Applied Optics, **42**, 10 pg. 1882 (2003).